

IMPORTANT SAFETY INSTRUCTIONS

WARNING

To reduce the risk of injury or death to persons

- 1) **READ AND FOLLOW ALL INSTRUCTIONS**
- 2) Disconnect power supply before attempting installation
- 3) For use with a Class 2 supply +6V DC to +40V DC
- 4) For use as entrapment protection device on doors or gates
- 5) Refer to door or gate operator manual for details of accurate connection to the operator
- 6) OPTOEYE photo eyes are to be placed at the bottom of the opening no more than 6 inches (doors)/ 27.5 inches (gates) from the ground
- 7) OPTOEDGE safety edges are to be placed where risk of entrapment or obstruction exists, such as the bottom edge of a vertically closing edge
- 8) **SAVE THESE INSTRUCTIONS**

Description

The OPTOEDGE and OPTOEYE are entrapment protection devices to safeguard doors or gates acc. to the requirements of UL325. The same optical sensors are used for both systems: for the photo eye OPTOEYE and the sensing edge OPTOEDGE.

Technical Data

| | |
|-------------------|----------------|
| Power Consumption | max. 50 mA |
| Supply Voltage | 6 to 40V DC |
| Operation Temp. | -13°F to 165°F |
| Range: | |
| Safety Edge | 30 ft. |
| Photo Eye | 45 ft. |

INSTALLATION OPTOEYE

Required Tools:



1. Mount photo eye at the door/ gate opening
2. Plug sensors into flexible adapters

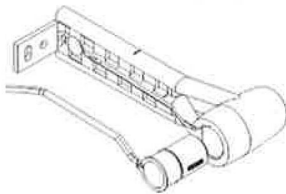

ATTENTION!
Coded Sensors

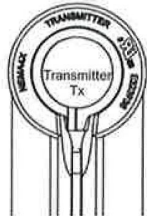

3. Wire photo eyes to the operator and connect to the monitored interface
4. Align transmitter and receiver by adjusting angle and height of the fixture

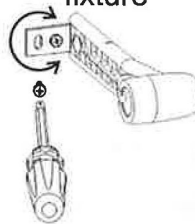

Angle adjustment

Height adjustment (first loosen wing nut)



Utilize LED'S for alignment and trouble-shooting:

| Red LED | Green LED | Status |
|-----------|-----------|--|
| On | On | Normal Operation |
| Off | Off | No Power, Check wiring |
| 2 x Blink | On | Bad alignment/ Obstructed beam/ Rx defective |
| 2 x Blink | Off | Check power & wiring to Rx/ Rx defective |
| 3 x Blink | On | Rx receiving sunlight/ interference |

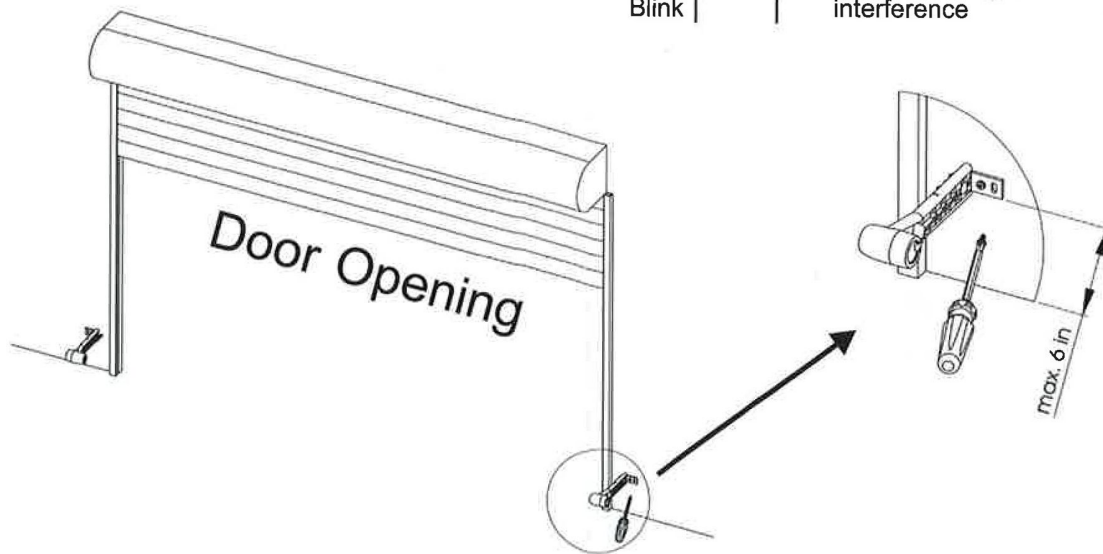
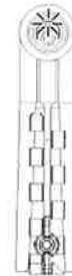

INSTALLATION OPTOEDGE

Required Tools:

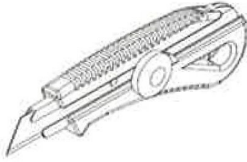

1. Measure and cut the required length of rubber profile (E)
2. Mount an applicable retainer (D) to the bottom edge of the door (A) or the leading edge and pinch-points of the gate
3. Slide the rubber profile (E) on the retainer (D)
4. Plug the sensors (F) into the circular hollow chamber of the rubber profile (E)
5. Wire the sensor cable into a junction box (C) and connect them to a coil cord (B)
6. Connect the opposite end of the coil cord (B) to the monitored interface of the operator

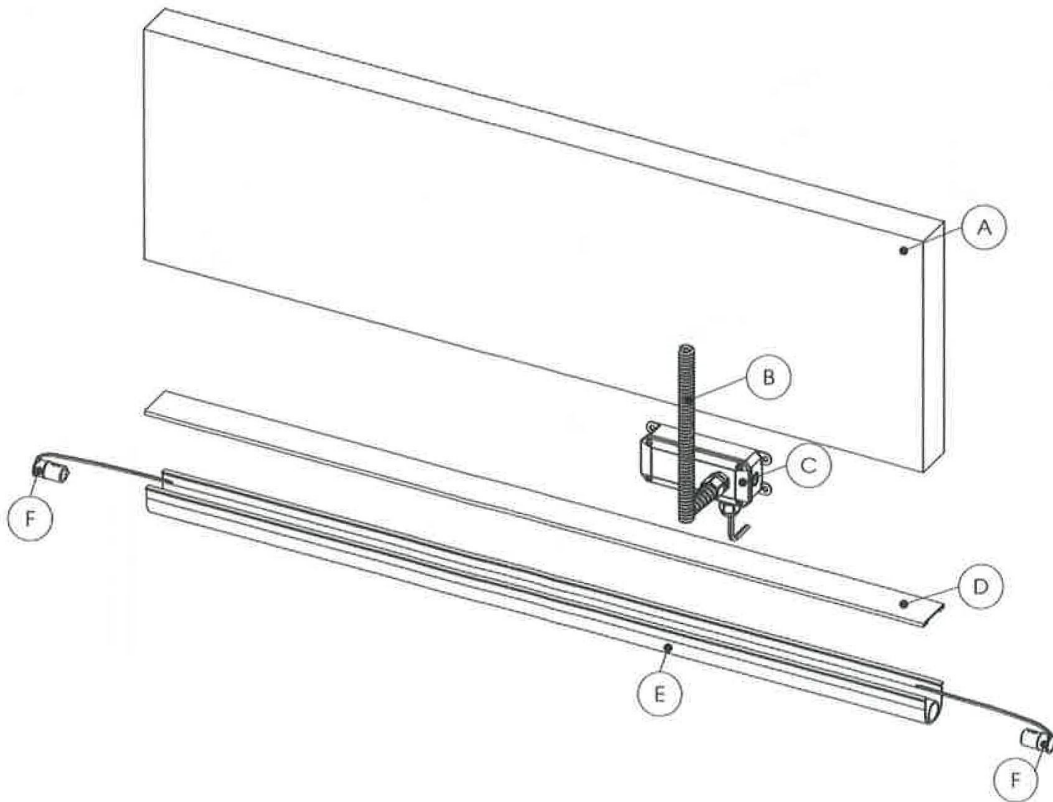

INSTALLATION DOORS AND GATES

Doors and Gates must be equipped with entrapment protection devices to avoid danger of injury to persons. Before installation of such devices, the installer has to identify all danger zones of the door or gate.

Doors

Install non-contact sensor in the door opening not higher than 6 in. from the ground

OR

Install contact sensors on the leading edge of the door

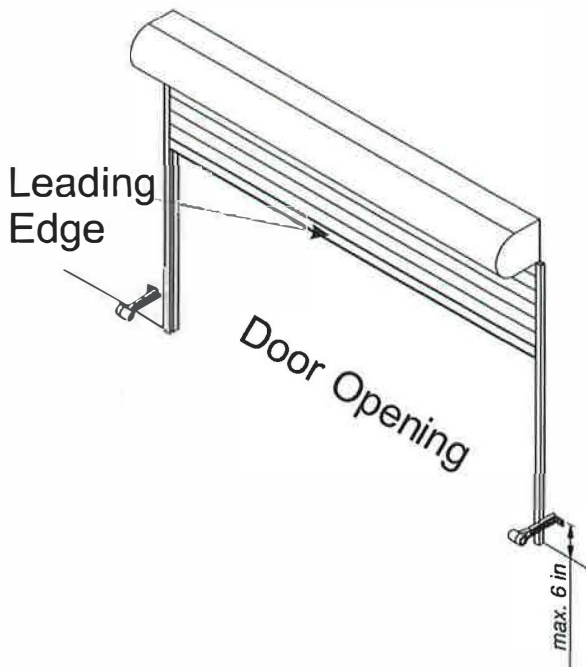

Gates

Install non-contact sensor in the gate opening not higher than 27 1/2 in. from the ground

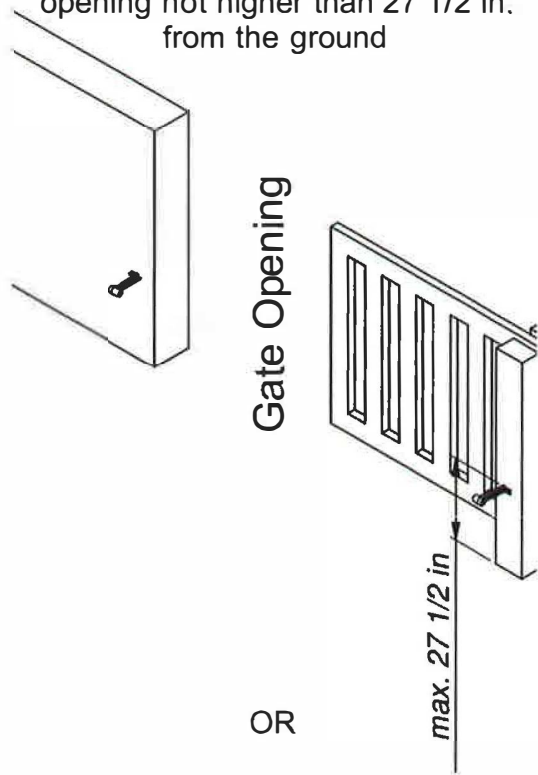

OR

Install contact sensor on the leading edge of the gate and all other identified pinch-points

